



Cetra® 536 Plus Whirlpool Bath with Integral Skirt

BP99 Cetra® 536 Plus Whirlpool Bath with Integral Skirt
Right Hand

BP93 Cetra® Plus Whirlpool Bath with Integral Skirt
Left Hand

- Right and Left Hand Drain Location
- Accessories / Hardware:
 - Trip-Lever Drain Kit: #X559
 - Rotary Drain Kit, 26" Cable: #8730
 - TheraPro™ Jet Rings Kit: #GU44
 - AccuPro™ Jet Rings Kit (3 Req'd): #GU45
- Trim Kit Finishes Available:
 - (827) – Chrome
 - (826) – Brushed Nickel
 - (845) – Oil Rubbed Bronze

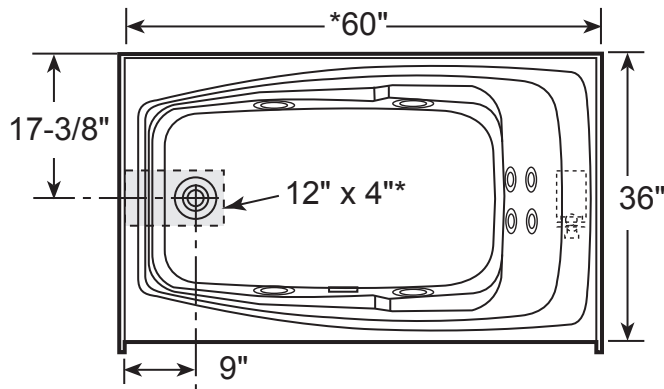

Product Shown: Cetra® 536 Plus Whirlpool Bath with Integral Skirt Left Hand Model: BP93

* Measurements inside unit represent cutout in floor to allow for drain/overflow.

INSTALLATION NOTES

Refer to installation instructions included with fixture before beginning installation. Please confirm product availability and specifications before commencing with any installation work.

PRODUCT SPECIFICATIONS AND AVAILABILITY ARE SUBJECT TO CHANGE WITHOUT NOTICE.

Technical Specifications

DIMENSIONS

60" L x 36" W x 21-1/4" H
(1524 mm) L x (914 mm) W x (540 mm) H

DRAIN/OVERFLOW

A: 18-1/2" (470 mm) B: 9" (229 mm)

CUTOUT

Not Applicable

TOTAL WEIGHT

858 lb (389 kg) / 57 lb/sq. ft. (278 kg/m²)

OPERATING GALLONAGE

Min. 41 U.S. Gal. (155 Liters)
Max. 62 U.S. Gal. (235 Liters)

PRODUCT WEIGHT

92 lb (42 kg)

SKIRT MOUNTING

Integral

ELECTRICAL SPECIFICATIONS

Requires a dedicated GFCI protected separate circuit.
Motor/Pump: 120 VAC, 15 AMP, 60 Hz.
RapidHeat™: 120 VAC, 15 AMP, 60 Hz.

HEATER(STANDARD)

Requires a dedicated GFCI protected separate circuit.
RapidHeat™: P/N S750000

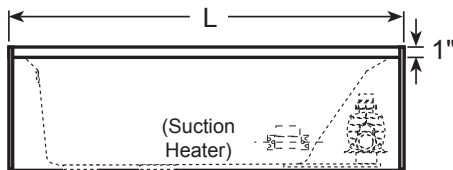

SIDE VIEW

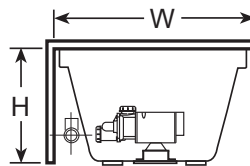

END VIEW

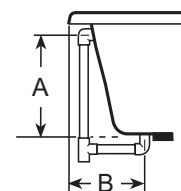

DRAIN/OVERFLOW